

Caratteristiche tecniche

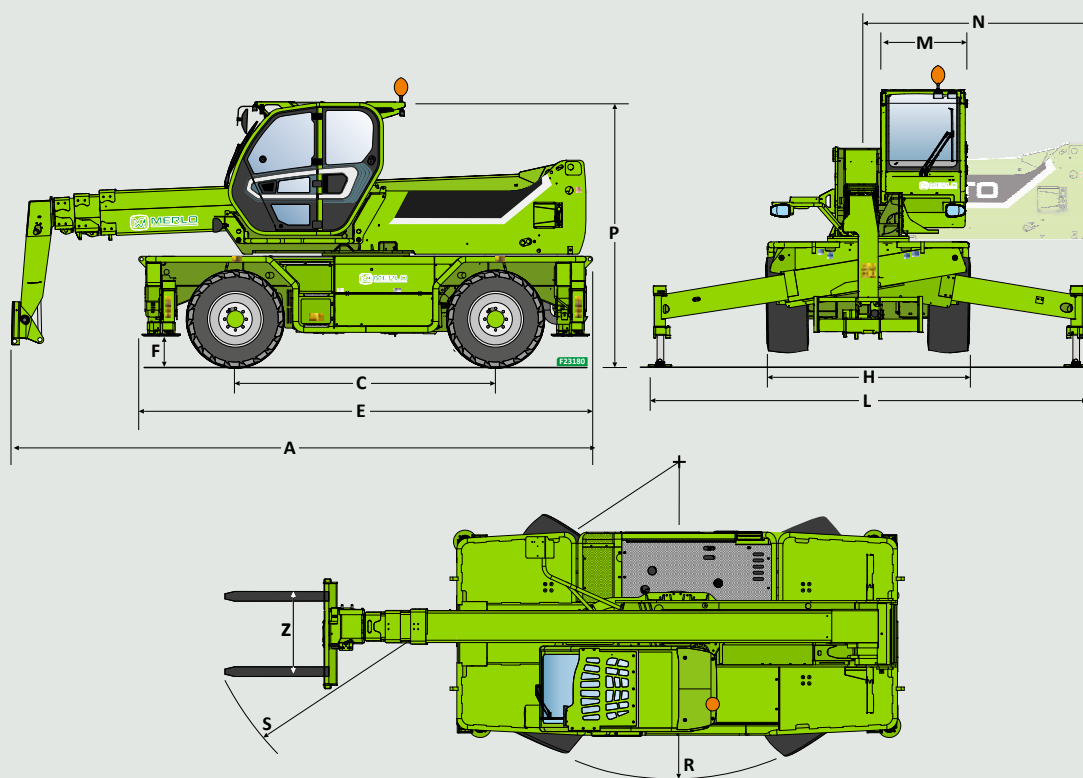

Dimensioni			A	C	E	F	H	L	M	P	R	S	N
ROTO 400	ROTO 40.16	mm	6280	2860	4750	290	2240	3750	1010	2980	4000	5930	2300
	ROTO 40.16 S	mm	6280	2860	4750	290	2240	3750	1010	2980	4000	5930	2300
	ROTO 40.18	mm	6030	2860	4750	290	2240	3750	1010	2980	4000	5750	2300
	ROTO 40.18 S	mm	6030	2860	4750	290	2240	3750	1010	2980	4000	5750	2300
ROTO Big	ROTO 50.21	mm	6830	3070	5370	370	2430	5010	1010	3120	3850	6100	2600
	ROTO 50.21 S	mm	6830	3070	5370	370	2430	5010	1010	3120	3850	6100	2600
	ROTO 50.21 S Plus	mm	6830	3070	5370	370	2430	5010	1010	3120	3850	6100	2600
	ROTO 50.26	mm	7150	3070	5370	370	2430	5010	1010	3120	3850	6310	2600
	ROTO 50.26 S	mm	7150	3070	5370	370	2430	5010	1010	3120	3850	6310	2600
	ROTO 50.26 S Plus	mm	7150	3070	5370	370	2430	5010	1010	3120	3850	6310	2600
	ROTO 50.30 S Plus	mm	7790	3200	5620	290	2490	5260	1010	3160	4500	6770	3170
	ROTO 70.24 S Plus	mm	7545	3200	5620	290	2490	5260	1010	3160	4500	6770	3170
ROTO "35"	ROTO 50.35 Plus	mm	8590	3780	6910	315	2540	6320	995	3325	4840	7130	3690
	ROTO 70.28 Plus	mm	8310	3780	6910	315	2540	6320	995	3325	4840	6920	3690

	ROTO 16-18				ROTO 21-26					
Modello	ROTO40.16	ROTO40.16 S	ROTO40.18	ROTO40.18 S	ROTO50.21	ROTO50.21 S	ROTO50.21 S PLUS	ROTO50.26	ROTO50.26 S	ROTO50.26 S PLUS
Prestazioni										
Massa totale a vuoto (kg)	12900	13000	13500	13600	15800	15800	16500	16600	16600	17300
Massima portata (kg)	4000	4000	4000	4000	4950	4950	4950	4950	4950	4950
Altezza di sollevamento (m)	15,8	15,8	17,7	17,7	21	21	21	25,9	25,9	25,9
Massimo sbraccio (m)	13,2	13,2	15	15	17,9	17,9	17,9	22,9	22,9	22,9
Livellamento del telaio (%)	-	+/-12, +/-4	-	+/-12, +/-4	-	+/-12, +/-4	+/-12, +/-4	-	+/-12, +/-4	+/-12, +/-4
Powertrain										
Motore	FPT F34	FPT F36	FPT F34	FPT F36	Deutz TCD3.6	FPT NEF45	FPT NEF45	Deutz TCD3.6	FPT NEF45	FPT NEF45
Potenza motore (kW/HP)	55,4/75	90/122	55,4/75	90/122	55,4/75	125/170	125/170	55,4/75	125/170	125/170
Tecnologia anti inquinamento	Stage V, DOC+DPF	Stage V, SCR+DOC+DPF	Stage V, DOC+DPF	Stage V, SCR+DOC+DPF	Stage V, DOC+DPF	Stage V, SCR+DOC+DPF	Stage V, SCR+DOC+DPF	Stage V, DOC+DPF	Stage V, SCR+DOC+DPF	Stage V, SCR+DOC+DPF
Velocità massima (km/h)	25	40	25	40	25	40	40	25	40	40
Serbatoio carburante (l)	140	140	140	140	150	150	150	150	150	150
Serbatoio AdBlue (l)	-	18	-	18	-	43	43	-	43	43
Trasmissione idrostatica	SI - 2V	SI - 2V	SI - 2V	SI - 2V	SI - 2V	SI - 2V	SI - 2V	SI - 2V	SI - 2V	SI - 2V
EPD	STD	STD	STD	STD	STD	STD	STD	STD	STD	STD
Idraulica										
Pompa idraulica	LS + FS	LS + FS	LS + FS	LS + FS	LS + FS	LS + FS	2 - LS + FS	LS + FS	LS + FS	2 - LS + FS
Portata/pressione (l/min - bar)	103,5 - 250	103,5 - 250	103,5 - 250	103,5 - 250	103,5 - 250	138 - 250	138+100 - 250/230	103,5 - 250	138 - 250	138+100 - 250/230
Serbatoio olio idraulico (l)	162	162	162	162	120	120	120	120	120	120
Cabina										
Allestimento cabina	PREMIUM	PREMIUM	PREMIUM	PREMIUM	PREMIUM	PREMIUM	PREMIUM	PREMIUM	PREMIUM	PREMIUM
ASCS	Completo	Completo	Completo	Completo	Completo	Completo	Completo	Completo	Completo	Completo
Cabina FOPS/ROPS	SI	SI	SI	SI	SI	SI	SI	SI	SI	SI
Comandi cabina	Joystick elettronico	Joystick elettronico	Joystick elettronico	Joystick elettronico	Joystick elettronico	Joystick elettronico	Joystick elettronico	Joystick elettronico	Joystick elettronico	Joystick elettronico
Cabina Basculante	-	-	-	-	NO	NO	SI	NO	NO	SI
Inversore	Dual reverse	Dual reverse	Dual reverse	Dual reverse	Dual reverse	Dual reverse	Dual reverse	Dual reverse	Dual reverse	Dual reverse
Configurazione										
Sospensioni su assale	NO	SI	NO	SI	NO	SI	SI	NO	SI	SI
Tac-lock	SI	SI	SI	SI	SI	SI	SI	SI	SI	SI
Predisposizione Navicella	SI	SI	SI	SI	SI	SI	SI	SI	SI	SI
Trazione integrale	SI	SI	SI	SI	SI	SI	SI	SI	SI	SI
4 ruote sterzanti, tre modi di sterzata	SI	SI	SI	SI	SI	SI	SI	SI	SI	SI
Pneumatici standard	400/70-20	400/70-20	400/70-20	400/70-20	18-22.5	18-22.5	18-22.5	18-22.5	18-22.5	18-22.5
Stabilizzatori	On/Off	On/Off	On/Off	On/Off	Multi-position	Multi-position	Multi-position	Multi-position	Multi-position	Multi-position
Rotazione torretta	415°	415°	415°	415°	600°	Continua	Continua	600°	Continua	Continua

Caractéristiques techniques

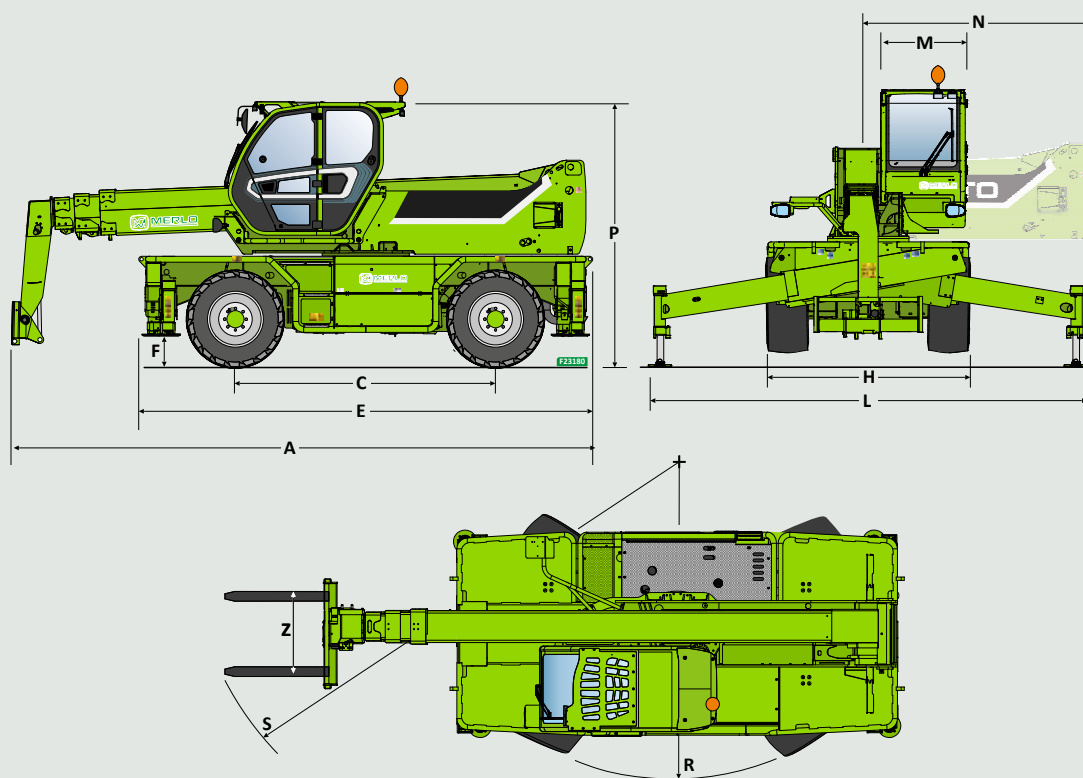

Dimensions			A	C	E	F	H	L	M	P	R	S	N
ROTO 400	ROTO 40.16	mm	6280	2860	4750	290	2240	3750	1010	2980	4000	5930	2300
	ROTO 40.16 S	mm	6280	2860	4750	290	2240	3750	1010	2980	4000	5930	2300
	ROTO 40.18	mm	6030	2860	4750	290	2240	3750	1010	2980	4000	5750	2300
	ROTO 40.18 S	mm	6030	2860	4750	290	2240	3750	1010	2980	4000	5750	2300
ROTO Big	ROTO 50.21	mm	6830	3070	5370	370	2430	5010	1010	3120	3850	6100	2600
	ROTO 50.21 S	mm	6830	3070	5370	370	2430	5010	1010	3120	3850	6100	2600
	ROTO 50.21 S Plus	mm	6830	3070	5370	370	2430	5010	1010	3120	3850	6100	2600
	ROTO 50.26	mm	7150	3070	5370	370	2430	5010	1010	3120	3850	6310	2600
	ROTO 50.26 S	mm	7150	3070	5370	370	2430	5010	1010	3120	3850	6310	2600
	ROTO 50.26 S Plus	mm	7150	3070	5370	370	2430	5010	1010	3120	3850	6310	2600
	ROTO 50.30 S Plus	mm	7790	3200	5620	290	2490	5260	1010	3160	4500	6770	3170
	ROTO 70.24 S Plus	mm	7545	3200	5620	290	2490	5260	1010	3160	4500	6770	3170
ROTO « 35 »	ROTO 50.35 Plus	mm	8590	3780	6910	315	2540	6320	995	3325	4840	7130	3690
	ROTO 70.28 Plus	mm	8310	3780	6910	315	2540	6320	995	3325	4840	6920	3690

	ROTO 16-18				ROTO 21-26					
Modèle	ROTO40.16	ROTO40.16 S	ROTO40.18	ROTO40.18 S	ROTO50.21	ROTO50.21 S	ROTO50.21 S PLUS	ROTO50.26	ROTO50.26 S	ROTO50.26 S PLUS
Performances										
Masse totale à vide (kg)	12900	13000	13500	13600	15800	15800	16500	16600	16600	17300
Capacité maximale (kg)	4000	4000	4000	4000	4950	4950	4950	4950	4950	4950
Hauteur de levage (m)	15,8	15,8	17,7	17,7	21	21	21	25,9	25,9	25,9
Portée maximale (m)	13,2	13,2	15	15	17,9	17,9	17,9	22,9	22,9	22,9
Mise à niveau du châssis (%)	-	+/-12, +/-4	-	+/-12, +/-4	-	+/-12, +/-4	+/-12, +/-4	-	+/-12, +/-4	+/-12, +/-4
Powertrain										
Moteur	FPT F34	FPT F36	FPT F34	FPT F36	Deutz TCD3.6	FPT NEF45	FPT NEF45	Deutz TCD3.6	FPT NEF45	FPT NEF45
Puissance moteur (kW/HP)	55,4/75	90/122	55,4/75	90/122	55,4/75	125/170	125/170	55,4/75	125/170	125/170
Technologie anti-pollution	Stage V, DOC+DPF	Stage V, SCR+DOC+DPF	Stage V, DOC+DPF	Stage V, SCR+DOC+DPF	Stage V, DOC+DPF	Stage V, SCR+DOC+DPF	Stage V, SCR+DOC+DPF	Stage V, DOC+DPF	Stage V, SCR+DOC+DPF	Stage V, SCR+DOC+DPF
Vitesse maximale (km/h)	25	40	25	40	25	40	40	25	40	40
Réservoir de carburant (l)	140	140	140	140	150	150	150	150	150	150
Réservoir d'adblue (l)	-	18	-	18	-	43	43	-	43	43
Transmission hydrostatique	OUI - 2V	OUI - 2V	OUI - 2V	OUI - 2V	OUI - 2V	OUI - 2V	OUI - 2V	OUI - 2V	OUI - 2V	OUI - 2V
EPD	STANDARD	STANDARD	STANDARD	STANDARD	STANDARD	STANDARD	STANDARD	STANDARD	STANDARD	STANDARD
Hydraulique										
Pompe hydraulique	LS + FS	LS + FS	LS + FS	LS + FS	LS + FS	LS + FS	2 - LS + FS	LS + FS	LS + FS	2 - LS + FS
Débit / pression (l/min - bar)	103,5 - 250	103,5 - 250	103,5 - 250	103,5 - 250	103,5 - 250	138 - 250	138+100 - 250/230	103,5 - 250	138 - 250	138+100 - 250/230
Réservoir d'huile hydraulique (l)	162	162	162	162	120	120	120	120	120	120
Cabine										
Préparation cabine	PREMIUM	PREMIUM	PREMIUM	PREMIUM	PREMIUM	PREMIUM	PREMIUM	PREMIUM	PREMIUM	PREMIUM
ASCS	Complet	Complet	Complet	Complet	Complet	Complet	Complet	Complet	Complet	Complet
Cabine FOPS/ROPS	OUI	OUI	OUI	OUI	OUI	OUI	OUI	OUI	OUI	OUI
Commandes cabine	Joystick électronique	Joystick électronique	Joystick électronique	Joystick électronique	Joystick électronique	Joystick électronique	Joystick électronique	Joystick électronique	Joystick électronique	Joystick électronique
Cabine inclinable	-	-	-	-	NON	NON	OUI	NON	NON	OUI
Inverseur	Double inversion	Double inversion	Double inversion	Double inversion	Double inversion	Double inversion	Double inversion	Double inversion	Double inversion	Double inversion
Configuration										
Suspensions hydropneumatiques du pont EAS	NON	OUI	NON	OUI	NON	OUI	OUI	NON	OUI	OUI
Tac-lock	OUI	OUI	OUI	OUI	OUI	OUI	OUI	OUI	OUI	OUI
Prédisposition Nacelle	OUI	OUI	OUI	OUI	OUI	OUI	OUI	OUI	OUI	OUI
Quatre roues motrices	OUI	OUI	OUI	OUI	OUI	OUI	OUI	OUI	OUI	OUI
4 roues directrices, trois types de braquage	OUI	OUI	OUI	OUI	OUI	OUI	OUI	OUI	OUI	OUI
Pneus standard	400/70-20	400/70-20	400/70-20	400/70-20	18-22,5	18-22,5	18-22,5	18-22,5	18-22,5	18-22,5
Stabilisateurs	On/Off	On/Off	On/Off	On/Off	Multiposition	Multiposition	Multiposition	Multiposition	Multiposition	Multiposition
Rotation de la tourelle	415°	415°	415°	415°	600°	Continue	Continue	600°	Continue	Continue

Technical characteristics

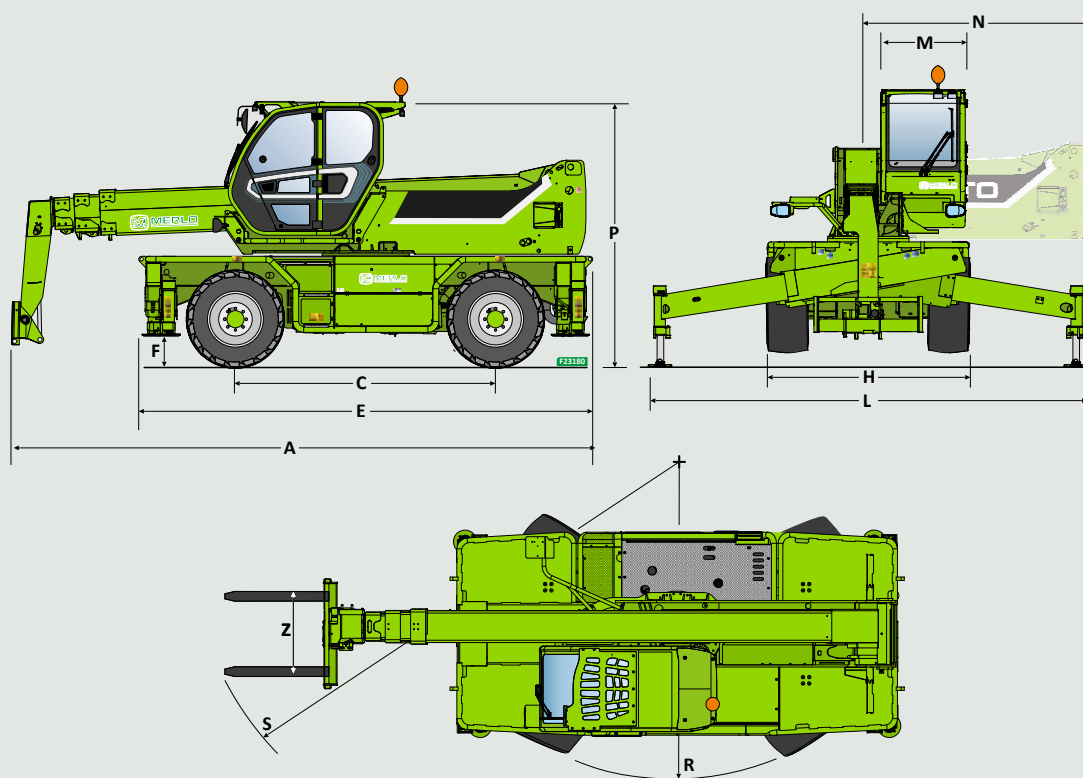

Dimensions			A	C	E	F	H	L	M	P	R	S	N
ROTO 400	ROTO 40.16	mm	6280	2860	4750	290	2240	3750	1010	2980	4000	5930	2300
	ROTO 40.16 S	mm	6280	2860	4750	290	2240	3750	1010	2980	4000	5930	2300
	ROTO 40.18	mm	6030	2860	4750	290	2240	3750	1010	2980	4000	5750	2300
	ROTO 40.18 S	mm	6030	2860	4750	290	2240	3750	1010	2980	4000	5750	2300
ROTO Big	ROTO 50.21	mm	6830	3070	5370	370	2430	5010	1010	3120	3850	6100	2600
	ROTO 50.21 S	mm	6830	3070	5370	370	2430	5010	1010	3120	3850	6100	2600
	ROTO 50.21 S Plus	mm	6830	3070	5370	370	2430	5010	1010	3120	3850	6100	2600
	ROTO 50.26	mm	7150	3070	5370	370	2430	5010	1010	3120	3850	6310	2600
	ROTO 50.26 S	mm	7150	3070	5370	370	2430	5010	1010	3120	3850	6310	2600
	ROTO 50.26 S Plus	mm	7150	3070	5370	370	2430	5010	1010	3120	3850	6310	2600
	ROTO 50.30 S Plus	mm	7790	3200	5620	290	2490	5260	1010	3160	4500	6770	3170
ROTO 70.24 S Plus	mm	7545	3200	5620	290	2490	5260	1010	3160	4500	6770	3170	
ROTO "35"	ROTO 50.35 Plus	mm	8590	3780	6910	315	2540	6320	995	3325	4840	7130	3690
	ROTO 70.28 Plus	mm	8310	3780	6910	315	2540	6320	995	3325	4840	6920	3690

	ROTO 16-18				ROTO 21-26					
Model	ROTO40.16	ROTO40.16 S	ROTO40.18	ROTO40.18 S	ROTO50.21	ROTO50.21 S	ROTO50.21 S PLUS	ROTO50.26	ROTO50.26 S	ROTO50.26 S PLUS
Performance										
Unladen weight (kg)	12900	13000	13500	13600	15800	15800	16500	16600	16600	17300
Maximum load capacity (kg)	4000	4000	4000	4000	4950	4950	4950	4950	4950	4950
Lift height (m)	15.8	15.8	17.7	17.7	21	21	21	25.9	25.9	25.9
Maximum reach (m)	13.2	13.2	15	15	17.9	17.9	17.9	22.9	22.9	22.9
Frame levelling (%)	-	+/-12, +/-4	-	+/-12, +/-4	-	+/-12, +/-4	+/-12, +/-4	-	+/-12, +/-4	+/-12, +/-4
Powertrain										
Engine	FPT F34	FPT F36	FPT F34	FPT F36	Deutz TCD3.6	FPT NEF45	FPT NEF45	Deutz TCD3.6	FPT NEF45	FPT NEF45
Engine power (kW/HP)	55,4/75	90/122	55,4/75	90/122	55,4/75	125/170	125/170	55,4/75	125/170	125/170
Anti-pollution technology	Stage V, DOC+DPF	Stage V, SCR+DOC+DPF	Stage V, DOC+DPF	Stage V, SCR+DOC+DPF	Stage V, DOC+DPF	Stage V, SCR+DOC+DPF	Stage V, SCR+DOC+DPF	Stage V, DOC+DPF	Stage V, SCR+DOC+DPF	Stage V, SCR+DOC+DPF
Maximum speed (km/h)	25	40	25	40	25	40	40	25	40	40
Fuel tank capacity (l)	140	140	140	140	150	150	150	150	150	150
Adblue tank capacity (l)	-	18	-	18	-	43	43	-	43	43
Hydrostatic transmission	YES - 2V	YES - 2V	YES - 2V	YES - 2V	YES - 2V	YES - 2V	YES - 2V	YES - 2V	YES - 2V	YES - 2V
EPD	STD	STD	STD	STD	STD	STD	STD	STD	STD	STD
Hydraulic system										
Hydraulic pump	LS + FS	LS + FS	LS + FS	LS + FS	LS + FS	LS + FS	2 - LS + FS	LS + FS	LS + FS	2 - LS + FS
Delivery/pressure (l/min-bar)	103.5 - 250	103.5 - 250	103.5 - 250	103.5 - 250	103.5 - 250	138 - 250	138+100 - 250/230	103.5 - 250	138 - 250	138+100 - 250/230
Hydraulic oil tank capacity (l)	162	162	162	162	120	120	120	120	120	120
Cab										
Cab finishing	PREMIUM	PREMIUM	PREMIUM	PREMIUM	PREMIUM	PREMIUM	PREMIUM	PREMIUM	PREMIUM	PREMIUM
ASCS	Full	Full	Full	Full	Full	Full	Full	Full	Full	Full
FOPS/ROPS Cab	YES	YES	YES	YES	YES	YES	YES	YES	YES	YES
Controls	Electronic joystick control	Electronic joystick control	Electronic joystick control	Electronic joystick control	Electronic joystick control	Electronic joystick control	Electronic joystick control	Electronic joystick control	Electronic joystick control	Electronic joystick control
Tilting Cab	-	-	-	-	NO	NO	YES	NO	NO	YES
Reverse shuttle	Dual reverse	Dual reverse	Dual reverse	Dual reverse	Dual reverse	Dual reverse	Dual reverse	Dual reverse	Dual reverse	Dual reverse
Configuration										
Hydropneumatic suspension	NO	YES	NO	YES	NO	YES	YES	NO	YES	YES
Tac-lock	YES	YES	YES	YES	YES	YES	YES	YES	YES	YES
Pre-arrangement for aerial work platform	YES	YES	YES	YES	YES	YES	YES	YES	YES	YES
Permanent four-wheel drive	YES	YES	YES	YES	YES	YES	YES	YES	YES	YES
4-wheel steering, with three steering modes	YES	YES	YES	YES	YES	YES	YES	YES	YES	YES
Standard tyres	400/70-20	400/70-20	400/70-20	400/70-20	18-22.5	18-22.5	18-22.5	18-22.5	18-22.5	18-22.5
Stabilisers	On/Off	On/Off	On/Off	On/Off	Multi-position	Multi-position	Multi-position	Multi-position	Multi-position	Multi-position
Turret rotation	415°	415°	415°	415°	600°	Continuous	Continuous	600°	Continuous	Continuous